

FLOW SENSORS

- ▶ **FT-110 Series –**
0.1 GPM to 8 GPM
(0.38 LPM to 30.3 LPM)
- ▶ **FT-210 Series –**
0.03 GPM to 0.66 GPM
(0.1 LPM to 2.5 LPM)

Features

- Small, compact size
- Low liquid flow rates
- Fast response time
- High accuracy $\pm 3\%$

Benefits

- Fits in tight spaces
- Reliable function at low flow rates
- Reacts quickly to starts & stops

Equipment Used On

- Dental sterilizers
- Tissue processing
- Heat exchanger for medical lasers
- Slide staining
- Hyper/Hypothermia systems

Flow Monitoring Applications

- Cooling loops
- Thermoregulation
- Wash/detergents

TurboFlow® Flow Rate Sensors



Gems TurboFlow® turbine flow rate sensors are ideal for medical equipment applications involving low flow liquid monitoring. The small turbine reacts quickly to on/off flow characteristics. This attribute, combined with a low cost and 0.5% repeatability, makes TurboFlow® sensors ideal candidates for replacing dispensing timer systems. Unlike existing timing systems, our proven turbine technology is not influenced by changes in system pressure caused by aging filters. Each sensor is 100% tested, ensuring years of service life. The sensor's standard power and output specifications make it easy to retrofit to existing controllers.

Operating Principle

Fluid flow causes a bladed rotor inside the TurboFlow® body to turn at an angular velocity directly proportional to the velocity of the fluid measured. As the blades pass beneath a magnetic pickup coil, a frequency signal is generated. Each pulse is equivalent to a discrete volume of fluid. The frequency pulse is directly proportional to the rotor angular velocity and the flow rate. The waves are readily transmitted to local or remote electrical instrumentation.

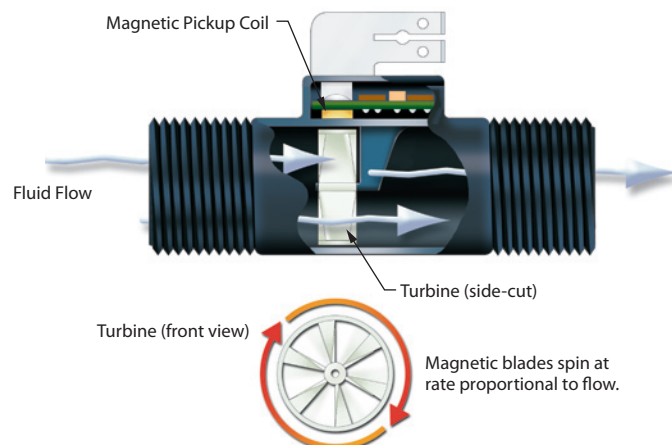

Specifications

FT-110

Flow Range	0.1 to 8 GPM (0.38 to 30.3 LPM)
Wetted Materials	
Body	Nylon 12
Turbine	Nylon 12 Composite
Bearings	PTFE/15% Graphite
Operating Pressure	200 PSI (14 bar)
Burst Pressure	2500 PSI (172 bar)
Operating Temperature	-4°F to 212°F (-20°C to 100°C)
Viscosity	32 to 81 SSU (.8 to 16 Centistokes)
Filter	<50 Microns
Input Power	5 to 24 VDC @ 8mA
Output (Hz)	NPN Sinking Open Collector @ 50mA Maximum (1 to 2.2K Ohm Pull-Up Resistor Required)
Accuracy	±3% of Reading
Repeatability	0.5% of Full Scale
Electrical Connection	Spade Terminals .110" x .248" x .031" (2.8/6.3 x .8 mm) or 3 ft. cable
Inlet/Outlet Ports	3/8" NPT Male (3/8" G Male also available)

FT-210

Flow Range	0.03 to 0.66 GPM (0.1 to 2.5 LPM)
Wetted Materials	
Body	Nylon 12 (Grilamid TR55)
Turbine	Nylon 12 Composite
Bearings	PTFE/15% Graphite
Operating Pressure	350 PSI (24 bar)
Burst Pressure	1400 PSI (97 bar)
Operating Temperature	-4°F to 212°F (-20°C to 100°C)
Viscosity	32 to 70 SSU (.8 to 16 Centistokes)
Filter	<50 Microns
Input Power	5 to 24 VDC
Output (Hz)	NPN Sinking Open Collector @ 20mA Maximum Leakage Current 10µA (2K-10K Pull up resistor required)
Accuracy	±3% of Reading
Repeatability	0.5% of Full Scale
Electrical Connection	9.4mm Spacing 3-pole DIN Connector (1" high)
Inlet/Outlet Ports	1/4" NPT (1/4" G Male also available)

Dimensions

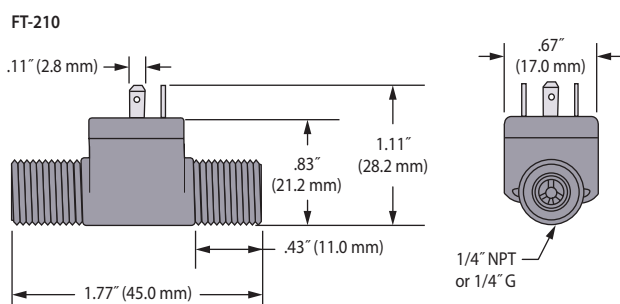
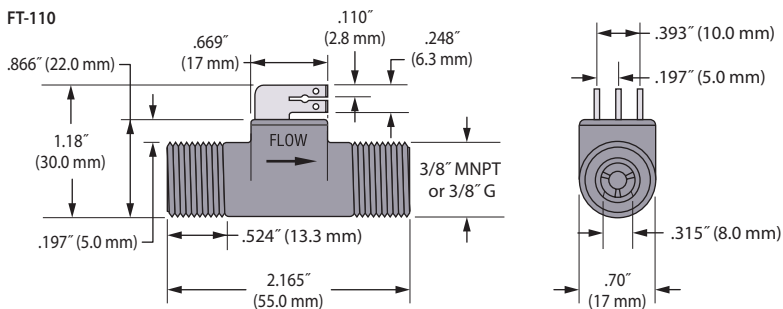

FT-110 Series

- 3/8" NPT, 3/8" G Male Ports
- Pressures to 200 PSI (14 bar)

Slightly larger than its sibling, the FT-210, Gems FT-110 sensors provide solid-state switching to flow rates up to 8 GPM. They are available with either spade connectors or a 3-conductor cable.

FT-210 Series

- 1/4" NPT, 1/4" G Male Ports
- Pressures to 350 PSI (24 bar)

At less than 2" long, the FT-210 is our most compact flow sensor. These units provide the same performance as the FT-110 Series for smaller flow lines and low flow rates. Electrical termination is designed for 3-pole DIN connector.

Our Medical Equipment Specialists are ready to discuss your sensor requirements, so don't hesitate to give us a call.



50 YEARS OF INNOVATION

GemsSensors.com

800.378.1600