

SOLENOID VALVES

Features

- Custom voltages and wattages
- Various flow orifices and pressure ranges
- Several diaphragm material options
- Multiple mounting and port configurations
- Minimal power consumption
- 100% performance tested
- Electrical connection via quick connect spade

Benefits

- Adaptable modular design
- Compact size
- Protects high purity media
- Broad fluid compatibility
- Hassle free installation reduces assembly time
- Low internal volume
- Minimal diaphragm displacement reduces pulsing
- Flexibility for single or multiple valve mounting

Equipment Used On

- Clinical chemistry
- Analytical
- Hematology
- Histology
- Immuno-chemistry
- Lab automation

Fluid Monitoring Applications

- Reagents
- High purity fluids
- Saline solution
- Perisitic acids
- Deionized water
- Solvent based fluids

Chem-S™ Miniature Inert Diaphragm Solenoid Valve



The Chem-S™ utilizes diaphragm technology in a liquid compatible, miniature inert isolation valve. With a compact size, flexible diaphragm design, low power consumption, and low cost, the Chem-S provides a unique and valuable option for the medical and scientific instrumentation industries. The Chem-S specifically targets the performance and price void between the limited pinch valve and the very expensive rocker style solenoid.

The Chem-S provides a new opportunity for the analytical and clinical chemistry industry. Its modular design coupled with Gems flexible engineering and manufacturing techniques, results in a truly adaptable valve that is easily integrated into any fluidic system.

Operating Principle

The Chem-S is a direct-acting inert solenoid valve with an internal diaphragm separating the plunger and guide assembly from the fluid passing through the valve; therefore, the fluid contacts only the inert valve body and the diaphragm material.

This inert 2-way valve has one inlet port and one outlet port. In the de-energized condition, the core spring holds the diaphragm seal on the valve seat to shut off the flow. When energized, the plunger is pulled into the solenoid coil and the diaphragm seal is lifted off the orifice seat, opening the valve. The electro-magnetic force is greater than the combined spring force and the static and dynamic pressure forces of the medium.

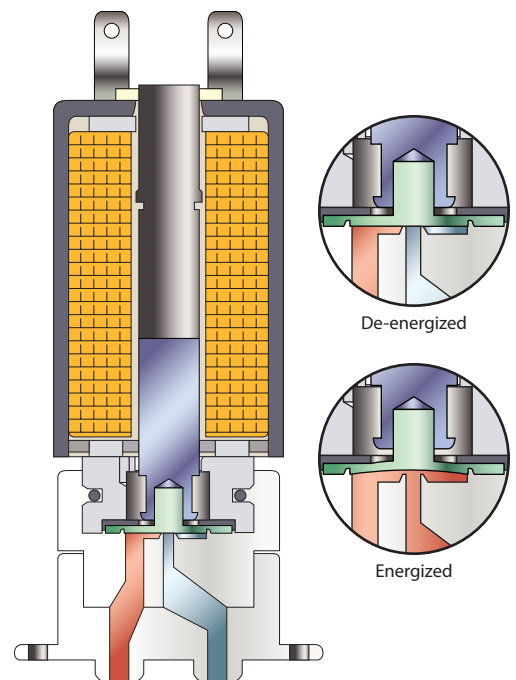

Specifications

All Gems valves are built-to-order. Custom options are available. Below are benchmark Chem-S valve specs.

Function	2-way normally closed
Media	Gas and liquid
Cv	0.016 at 70 psig and an orifice size of .031; 0.040 at 25 psig and an orifice size of .052
Port Configurations	1/8" barb; Face Mount; #10-32 thread flat bottom
Orifice Diameter	0.032" or 0.052"
Power Consumption	2 watts nominal
Maximum Operating Pressure	70 psi
Coil Construction	Quick connect .110 spade
Body Material	Polyurethane (Isoplast™)
Diaphragm Seal Materials	Viton®; EPDM
Voltage	5 VDC; 12 VDC; 24 VDC
Pressure Rated	Vacuum to 70 psig
Additional Options	Vacuum application (0 to 27" Hg)

Dimensions

1/8" I.D. Tube Barb Ports

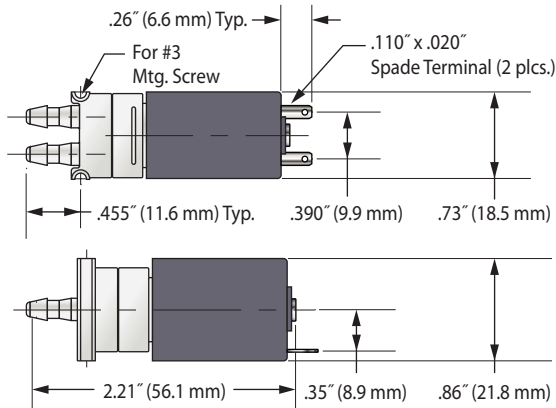

#10-32 UNF-2B Ports

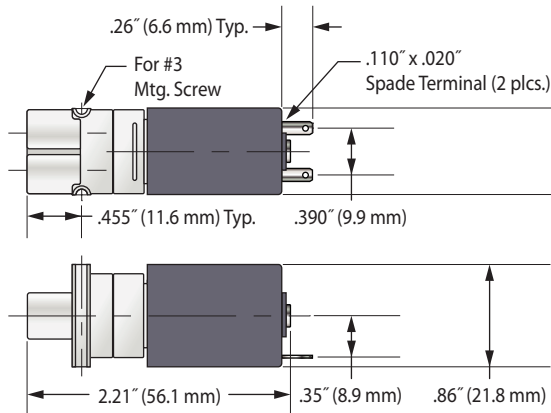

Manifold Mount Ports

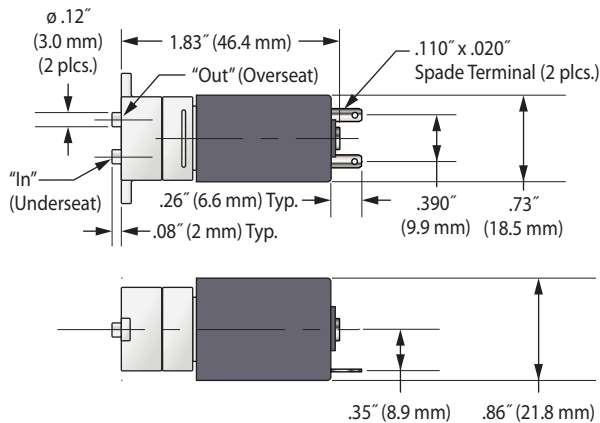

Fluid Port Options

1/8" I.D. Tube Barb Ports

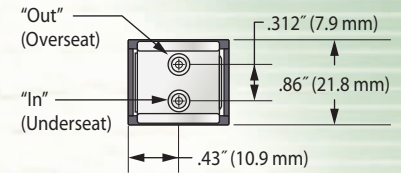

#10-32 UNF-2B Ports

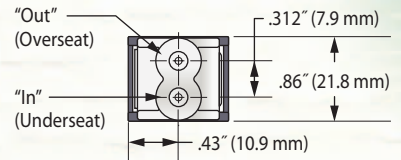

Manifold Mount Ports

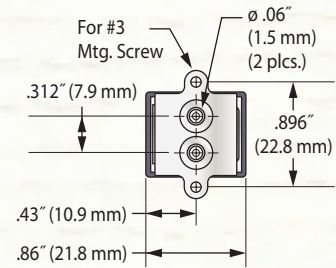

Manifold Assemblies



Gems PreDyne® valve engineers have over 30 years experience working with OEMs to design and manufacture integrated valve and manifold assemblies. We deliver fluidic systems that shorten development time, reduce assembly time, and increase product quality.

Our Medical Equipment Specialists are ready to discuss your sensor requirements, so don't hesitate to give us a call.



Our Experience • Your Solution

GemsMedicalSolutions.com

888.840.1230